

450  
PSI

DWG REF	QTY	PART NUMBER	DESCRIPTION	MATERIAL
<b>SHELL</b>				
1	1	99231	SHELL	Filament Wound Epoxy/Glass composites - Head locking grooves integrally wound in place.
2	A/R	A/R	F/C Port	SA-351 CF3M
3	A/R	A/R	F/C Port Seal	Ethylene Propylene .
<b>HEAD - NON CODED</b>				
4	2	96248	Elliptical Head Assy.	Engineering Thermoplastic.
4.1	2	194441	Elliptical Head	Engineering Thermoplastic.
4.2	2	96166	Danger Label	-
5	2	196223	Head Seal	Ethylene Propylene - O - Ring
<b>HEAD INTERLOCK</b>				
6	2	47336	Quick Release Spiral Ring	SA-479 SS316
<b>VESSEL SUPPORT</b>				
7	2*	52169	Saddle	Engineering Thermoplastic.
8	2*	45042	Strap Assy.	304 Stainless Steel-PVC Cushion.
9	4**	46265	Strap screw.	5/16-18 UNC,2.5" L, 304 Stainless Steel.
<b>ELEMENT INTERFACE</b>				
10	2	A/R	Adapter	Engineering Thermoplastic.
11	2	196222	Adapter seal	Ethylene Propylene - O - Ring
12	4	A/R	PWT Seal	Ethylene Propylene - O - Ring
13	1	97014	Thrust Cone	Engineering Thermoplastic.

\*3 & \*\*6 each furnished with length code 4,5,6,7 & 8.

**VIEW AT CENTER SUPPORT**  
CENTER VESSEL ON 2 OR 3 SUPPORTS  
AT SPAN(S) "S" : 3 SUPPORTS REQUIRED  
FOR LENGTHS -4 AND OVER

PORT SIZE CODE	
D	1 1/2" GROOVED END
E	2" GROOVED END
F	2 1/2" GROOVED END

**CAUTION: INCORRECT MANIFOLDING WILL CAUSE SEVERE LOCAL STRESS AROUND PORT AND MAY RESULT IN LEAKS AND PREMATURE FAILURE; TAKE EVERY PRECAUTION LISTED ON REVERSE. SEE INSTALLATION INSTRUCTIONS FOR FURTHER DETAILS**

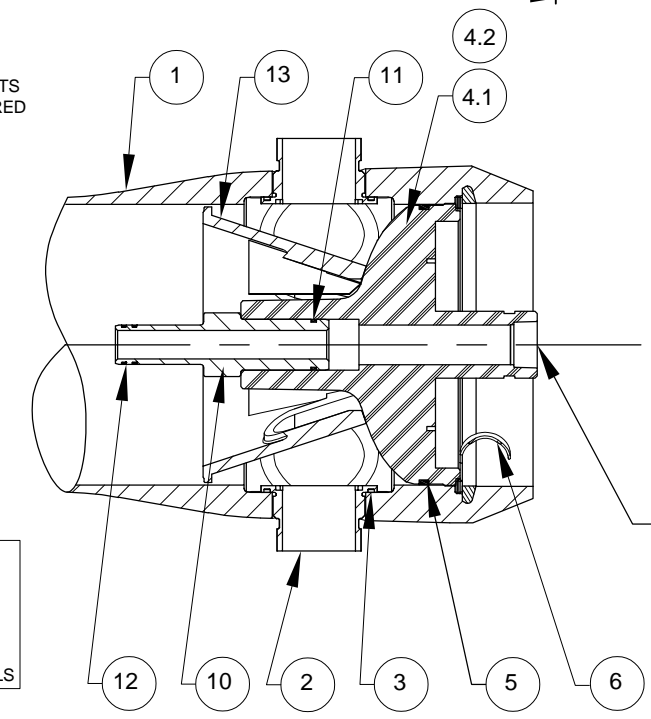

**WARNING** ⚠️  
INTERNAL PORT PRESSURE NOT TO EXCEED 125 PSI.

**SECTION THROUGH END CLOSURE**

Dash Length	PORT LOCATION			Approx Weight LB(KG)**
	L IN(MM)	P IN(MM)	S IN(MM)	
-1	59.75 (1518)	47 (1194)	20X1 (508)	70 (32)
-2	99.75 (2534)	87 (2210)	56X1 (1422)	90 (41)
-3	139.75 (3550)	127 (3226)	80X1 (2032)	108 (49)
-4	179.75 (4566)	167 (4242)	64X2 (1626)	121 (55)
-5	219.75 (5582)	207 (5258)	78X2 (1981)	143 (65)
-6	259.75 (6598)	247 (6274)	92X2 (2337)	159 (72)
-7	299.75 (7614)	287 (7290)	106X2 (2692)	178 (81)
-8	339.75 (8630)	327 (8306)	120X2 (3048)	194 (88)

**GENERAL NOTES:**  
1. MAX. ANGULAR VARIATION BETWEEN ANY PORT ±0.5°.  
2. DIMENSION IN INCHES (MM APPROX).  
3. SHELL EXTERIOR COATED WITH WHITE RAL 9003, HIGH GLOSS POLYURETHANE PAINT.  
4. ITEM 13 DOWNSTREAM ONLY.  
5. NOT TO BE USED FOR CONSTRUCTION UNLESS CERTIFIED BY PENTAIR.  
\*\* WEIGHTS GIVEN IN THE TABLE ARE FOR HIGHEST CONFIGURATION AND WILL VARY WITH CHANGE IN CONFIGURATION.

THIS DOCUMENT AND THE INFORMATION CONTAINED HEREIN, ARE THE CONFIDENTIAL AND PROPRIETARY INFORMATION OF PENTAIR WATER INDIA PVT. LTD. PENTAIR WATER INDIA PVT. LTD. IS THE SOLE OWNER OF THE INFORMATION AND PROCESSES DEFINED HEREIN. THIS DOCUMENT, AND THE INFORMATION CONTAINED, MAY NOT BE DISCLOSED, REPRODUCED, DUPLICATED, USED, SOLD, PUBLISHED, COMMUNICATED OR OTHERWISE DISTRIBUTED, IN WHOLE OR IN PART, FOR ANY PURPOSE WITHOUT THE EXPRESS WRITTEN CONSENT OF PENTAIR WATER INDIA PVT. LTD. THIS DOCUMENT AND ANY COPIES, IN ALL APPLICABLE FORMATS, SHALL BE RETURNED TO PENTAIR WATER INDIA PVT. LTD. UPON REQUEST.

ALL INDICATED PENTAIR TRADEMARKS AND LOGOS ARE PROPERTY OF PENTAIR. THIRD PARTY REGISTERED AND UNREGISTERED TRADEMARKS AND LOGOS ARE PROPERTY OF THEIR RESPECTIVE OWNERS. BECAUSE WE ARE CONTINUOUSLY IMPROVING OUR PRODUCTS AND SERVICES, PENTAIR RESERVES THE RIGHT TO CHANGE SPECIFICATIONS WITHOUT PRIOR NOTICE. PENTAIR IS AN EQUAL OPPORTUNITY EMPLOYER.

© 2021 Pentair. All Rights Reserved.

**PENTAIR CODELINE** VERNA, GOA INDIA

DRAWN BY: KR	DATE: 27DEC07	DRAWING DESCRIPTION: MODEL - 80S45 NC MEMBRANE HOUSING	DRAWING NO.: 99173	REV.: U
CHECKED BY: MD	DATE: 27DEC07	CUSTOMER NAME:	VESSEL MODEL: 80S45 (NON-CODED)	
APPROVED BY: SS	DATE: 27DEC07	PROJECT NAME:	TOTAL QTY: -	
ECN NO.: 6242	REV. DATE: 10NOV22	CUSTOMER P.O.#:	SIZE: A3	SCALE: NONE
			PAGE NO.: 01 OF 02	

**RATING:**

DESIGN PRESSURE.....	450 PSIG (3.10 MPa)
MAX. OPERATING TEMP .....	190°F (88°C)
MIN. OPERATING TEMP.....	20°F (-7°C)
FACTORY TEST PRESSURE.....	.675 PSIG (4.65 MPa)
QUALIFICATION PRESSURE.....	2700 PSI (18.62 MPa)

**INTENDED USE:**

The CodeLine 80S45 Non Coded Fiberglass RO Pressure Vessel is designed for continuous, long term use as housing for reverse osmosis membrane elements to desalt typical brackish waters at pressures up to 450 psi. Any make of eight-inch nominal diameter spiral-wound element is easily accommodated; the appropriate interfacing hardware for the element specified is furnished with the vessel.

The Shell of CodeLine 80S45 Non Coded vessel is designed in accordance with the engineering standards of the Boiler and Pressure Vessel Code of the American Society of Mechanical Engineers (ASME) as per Section X Edition 2021 and all metallic parts are designed as per ASME section VIII Division I Edition 2021.

The CodeLine 80S45 Non Coded vessel must be installed operated and maintained in accordance with the listed precautions and good industrial practice to assure safe operation over a long service life.

The high performance Filament wound FRP shell must be allowed to expand under pressure; undue restraint at support points or piping connections can cause leaks to develop in the shell. This side-ported vessel requires special precautions in mounting and connection to piping so that the vessel will not be subjected to excessive stress due to bending moments acting at the side openings in the fiberglass shell. The end closure, incorporating close fitting, interlocking metal components, must be kept dry and free of corrosion; deterioration can lead to catastrophic mechanical failure of the head.

Pentair will assist the purchaser in determining the suitability of this standard vessel for their specific operating conditions. The final determination however, including evaluation of the standard material of construction for compatibility with the specific corrosive environment, shall be the responsibility of the purchaser. Alternate materials with enhanced corrosion resistance are available on special order.

Specifications are subject to change without notice.

**PRECAUTIONS:**

- DO...read, understand and follow all instructions; failure to take every precaution will void warranty and may result in vessel failure
- DO...mount the shell on horizontal members at span "S" using compliant vessel supports furnished; Shim saddles if required. Tighten hold down straps just snug
- DO...align and center side ports with the manifold header. Correct causes of misalignment in a row of vessels connected to the same header
- DO...use flexible type IPS grooved-end pipe couplings, at side ports; allow full, 0.125 inch gap between port and piping, and position piping to maximize flexibility of connection.
- DO...provide flexibility in, and support for piping manifolds so that vessel can grow in length under pressure without undue restraint; provide additional flexible joints in large pipes leading to manifold header.
- DO...provide overpressure protection for vessel set at not more than 105% of design pressure
- DO...inspect end closures regularly; replace components that have deteriorated and correct causes of corrosion
- DO... Lubricate seals sparingly, using nonpetroleum Based lubricants, i.e. Parker Super O-lube®, Glycerin or suitable silicone based lubricants.

- DO NOT...work on any component until first verifying that pressure is relieved from vessel
- DO NOT...make rigid piping connections to ports or clamp vessel in any way that resists growth of fiberglass shell under pressure; \*\*\*ΔDIA = 0.015 in. (0.4mm) and \*\*\*ΔL = 0.2 in. (6mm) for a length code –8 vessel
- DO NOT... hang piping manifolds from ports or use vessel in any way to support other components
- DO NOT...tighten Permeate Port connection more than one turn past hand tight
- DO NOT... operate vessel without connecting both Permeate Ports internally to complete set of elements or otherwise plug ports internally so that external piping connection is not subjected to feed pressure
- DO NOT...install Spacer on downstream end of vessel
- DO NOT...operate vessel without Thrust Cone installed downstream
- DO NOT...pressurize vessel until double-checking to verify that the Locking Ring is in place and fully seated.
- DO NOT...operate vessel at pressure and temperature in excess of its rating.
- DO NOT...operate vessel with permeate pressure in excess of 125 psi at 190°F (0.86 MPa at 88°C).
- DO NOT...tolerate leaks or allow end closures to be routinely wetted in any way
- DO NOT...operate outside the pH range 3-11.

For complete information on proper use of the vessel Please refer to the 80S Series USER'S GUIDE 94182.

**ORDERING:**

Using the chart below, please check the features you require

**VESSEL LENGTH CODE – please check one**

MODEL 80S45 Non Coded  -1  -2  -3  -4  -5  -6  -7  -8

**MEMBRANE BRAND AND MODEL**

Please supply adapters for the following membrane brand and specific model  
Brand \_\_\_\_\_ Model \_\_\_\_\_

**CERTIFICATION REQUIRED**

Certified By Pentair.

ADAPTER KITS	
UP STREAM	DOWN STREAM

**PERMEATE PORT CONFIGURATION:**

- Standard. 1" FNPT & 1.5" IPS GROOVED NORYL HEAD.
- Optional .1" BSP F/JIS F Parallel Thread & 1.5" IPS GROOVED

**STRAP ASSEMBLY**

Standard SS304  Optional SS316  Optional SS316L

STRAP ASSEMBLY PART NUMBERS		
SS304	SS316	SS316L
45042	46926 <sup>+</sup>	94371 <sup>+</sup>

**FEED/CONCENTRATE PORT SELECTION**

Material of Construction  Standard CF3M  Optional Duplex SS (CD3MN)  
 Optional Super Duplex SS (CD3MWCuN)

Configuration  Standard - CF3M 1D5D

Optional – Multi ports :  
2.5" Ports not available in 90° Configuration.

Serial number end            
Opposite end

F/C PORT & SEAL PART NUMBER				
SIZE	*CF3M	**CD3MN	***CD3MWCuN	SEAL
1.5"	98024	97353	96507	196224
2.0"	98025	97357	96643	196225
2.5"	98026	97364	96556	196226

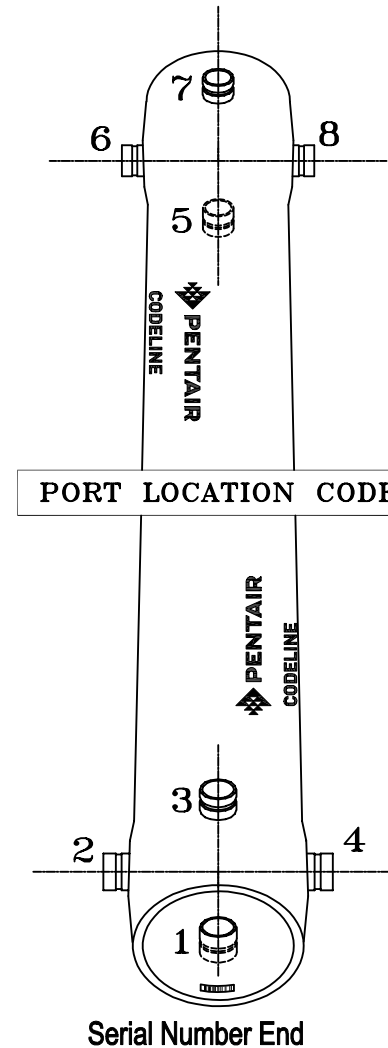

CODELINE BODY LABELS ARE PLACED AT 90° ON SERIAL NUMBER END AND AT 270° ON THE OPPOSITE SIDE END

**GENERAL NOTES:**

- DIMENSIONS IN INCHES (MM APPROX.).
- \* GRADE SA-351 CF3M.
- \*\* GRADE SA-995 CD3MN (UNS J92205).
- \*\*\* GRADE SA-995 CD3MWCuN (UNS J93380)
- + OPTIONAL STRAP ASSEMBLY WITH SS-316 & 316L SHALL BE SUPPLIED AS PER METRIC STANDARDS.

THIS DOCUMENT AND THE INFORMATION CONTAINED HEREIN, ARE THE CONFIDENTIAL AND PROPRIETARY INFORMATION OF PENTAIR WATER INDIA PVT. LTD. PENTAIR WATER INDIA PVT. LTD. IS THE SOLE OWNER OF THE INFORMATION AND PROCESSES DEFINED HEREIN. THIS DOCUMENT, AND THE INFORMATION CONTAINED, MAY NOT BE DISCLOSED, REPRODUCED, DUPLICATED, USED, SOLD, PUBLISHED, COMMUNICATED OR OTHERWISE DISTRIBUTED, IN WHOLE OR IN PART, FOR ANY PURPOSE WITHOUT THE EXPRESS WRITTEN CONSENT OF PENTAIR WATER INDIA PVT. LTD. THIS DOCUMENT AND ANY COPIES, IN ALL APPLICABLE FORMATS, SHALL BE RETURNED TO PENTAIR WATER INDIA PVT. LTD. UPON REQUEST.

ALL INDICATED PENTAIR TRADEMARKS AND LOGOS ARE PROPERTY OF PENTAIR. THIRD PARTY REGISTERED AND UNREGISTERED TRADEMARKS AND LOGOS ARE PROPERTY OF THEIR RESPECTIVE OWNERS. BECAUSE WE ARE CONTINUOUSLY IMPROVING OUR PRODUCTS AND SERVICES, PENTAIR RESERVES THE RIGHT TO CHANGE SPECIFICATIONS WITHOUT PRIOR NOTICE. PENTAIR IS AN EQUAL OPPORTUNITY EMPLOYER.

©2021 Pentair. All Rights Reserved.



DRAWN BY: KR	DRAWING DESCRIPTION: MODEL - 80S45 NC MEMBRANE HOUSING	DRAWING NO.: 99173	REV.: U
DATE: 27DEC07	CUSTOMER NAME:	VESSEL MODEL: 80S45 (NON-CODED)	
CHECKED BY: MD	PROJECT NAME:	TOTAL QTY: -	
DATE: 27DEC07	CUSTOMER P.O.#:	SIZE: A3	SCALE: NONE
APPROVED BY: SS	REV. DATE: 10NOV22	PAGE NO.: 02 OF 02	
DATE: 27DEC07			
ECN NO.: 6242			